



IMPORTANT

Bélanger recommends using a professional plumber for all installation and repair. Please inform yourself about the Canadian Plumbing Code's regulations and your local municipality plumbing codes before installation. The Canadian

Plumbing Code requires the installation of surge arresting devices to eliminate water hammering. **ALLOW AN ADEQUATE OPENING IN ORDER TO EASILY ACCESS CONNECTIONS OR OTHER PLUMBING DEVICES FOR MAINTENANCE OR REPAIR.**

Bélanger recommande de faire appel à un plombier compétent pour l'installation et la réparation de ce produit. Veuillez vous informer des différentes règles du Code Canadien de plomberie et des exigences de votre localité avant l'installation. Le Code Canadien de plomberie exige l'installation d'un dispositif anti-bélier afin d'amortir les coups de bélier dans la plomberie. **PRÉVOIR UNE OUVERTURE SUFFISANTE POUR FACILITER L'ACCÈS AUX RACCORDEMENTS OU À TOUT AUTRE DISPOSITIF DE PLOMBERIE EN VUE DE L'ENTRETIEN OU DE LA RÉPARATION.**

RECOMMENDED TOOLS / OUTILS RECOMMANDÉS

Thread seal tape

Ruban d'étanchéité pour joints filetés **

Included / Inclus



**Apply 2 turns of thread seal tape on threaded connections.

Appliquez 2 tours du ruban d'étanchéité sur les connexions filetés.

The model shown in the installation steps may differ from the one in box however connection type and installation steps are the same.

Le modèle démontré dans les étapes d'installation peut différer du produit en boîte, mais le type de connexions et d'installation demeure le même.

TECHNICAL DRAWING - DESSIN TECHNIQUE

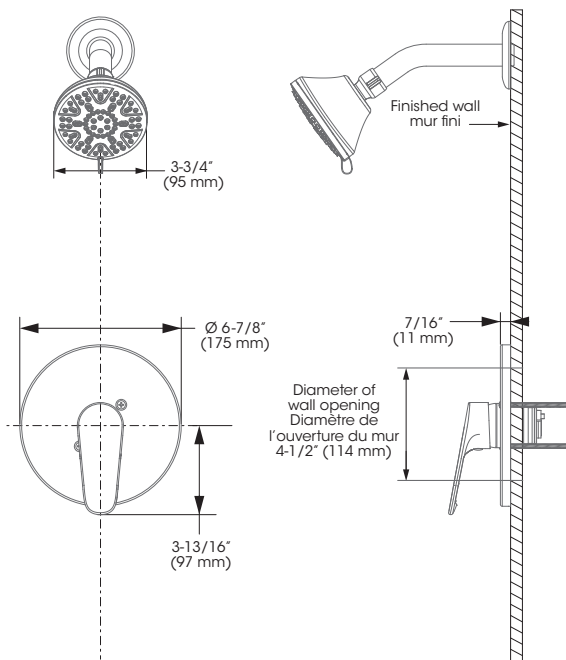

Quik

COLLECTION | 1000001914

KIT: SHOWER FAUCET - TRIM
ROBINET POUR DOUCHE - GARNITURE

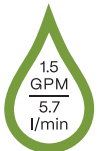

CARE INSTRUCTIONS

Rinse the product with clear water.
Dry the product with a soft cloth.

DO NOT use abrasive cleaners, cloths, or paper towels. **DO NOT USE OR EXPOSE TO** cleaning agents containing acid, polish, wax, alcohol, ammonia, bleach, solvents, or other harsh chemicals, household cleaners or corrosive substances.

INSTRUCTIONS D'ENTRETIEN

Rincer le robinet avec de l'eau claire et l'essuyer avec un tissu doux.

NE PAS utiliser des tissus ou essuie-tout abrasifs, produits nettoyants contenant de l'acide, agent polisseur, cires, alcool, ammoniac, eau de Javel, solvants ou tout autres produits agressif. **NE PAS EXPOSER** à des nettoyants ménagers ni à des substances corrosives.

Customer Service

Monday to Friday:
8 a.m. - 4:30 p.m. E.S.T.

Tel: 1-800-361-5960

Service à la clientèle

Lundi au vendredi:
8 h 00 à 16 h 30 H.N.E.

Fax: 1-888-533-8313

info@belangerfaucets.com

Replacement parts are available on order
Pièces de remplacement disponibles sur commande



For warranty details
Pour les détails sur la garantie
belangerfaucets.com



INSTALLATION STEPS - ÉTAPES D'INSTALLATION

BEFORE YOU BEGIN // AVANT DE COMMENCER

- * We insist on using copper pipe to connect the valve to the spout. PEX pipe adaptors can cause flow restriction, thus creating a backflow to the showerhead.
- * Nous insistons sur l'utilisation d'un tuyau de cuivre pour raccorder la valve au bec. Les adaptateurs de tuyau PEX peuvent causer une restriction de débit et un retour d'eau à la douche.

MAIN WATER VALVE
ENTRÉE D'EAU PRINCIPALE

OFF
FERMÉ



OPTION A: DRYWALL AND TILES
OPTION A : MUR DE GYPSE ET TUILES

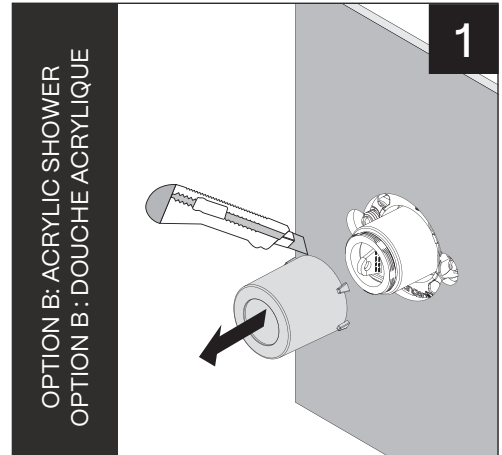
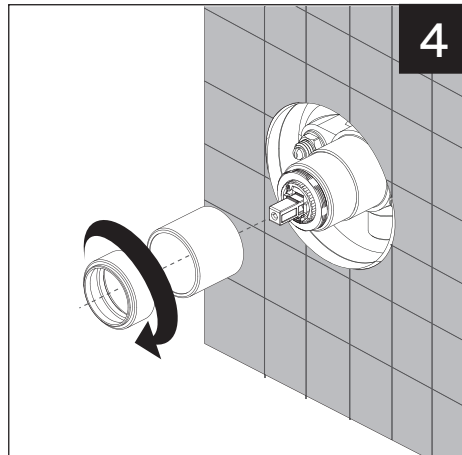
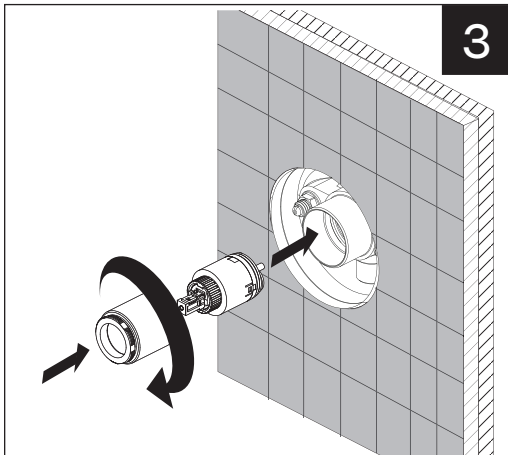
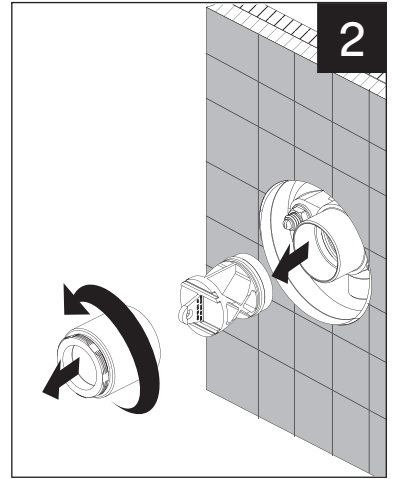
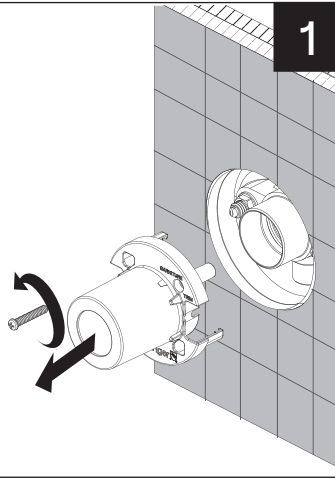

OPTION B: ACRYLIC SHOWER
OPTION B : DOUCHE ACRYLIQUE

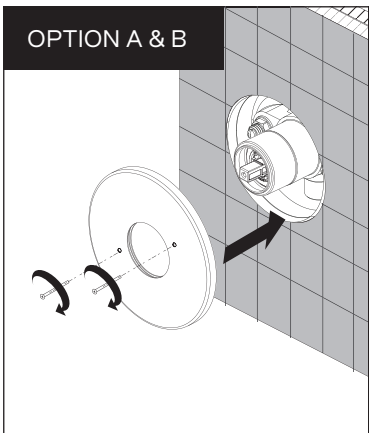
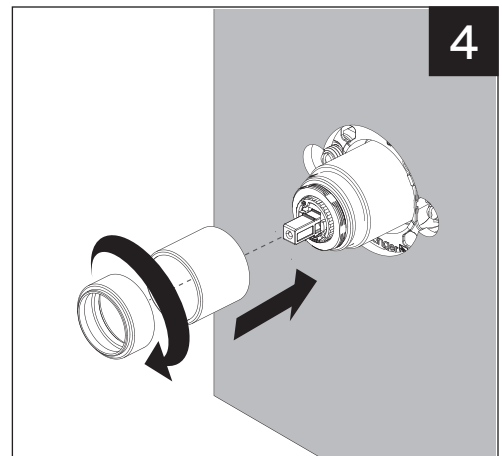
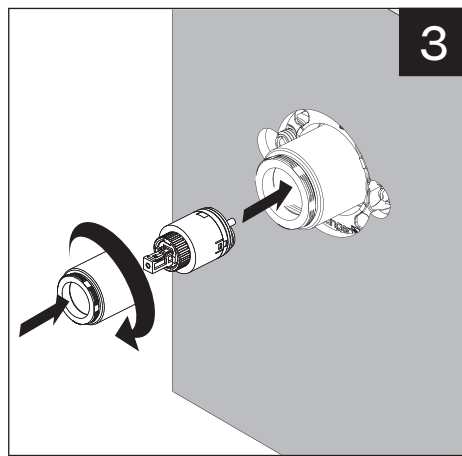
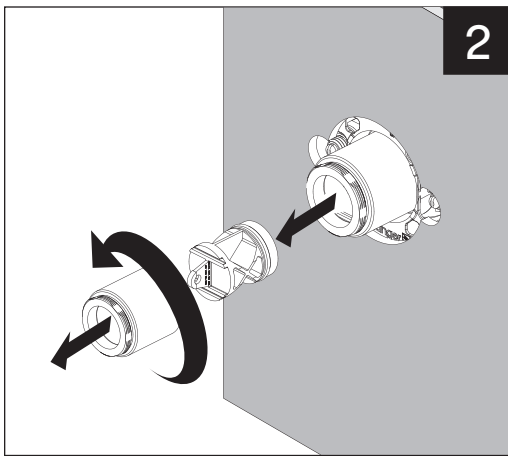

5

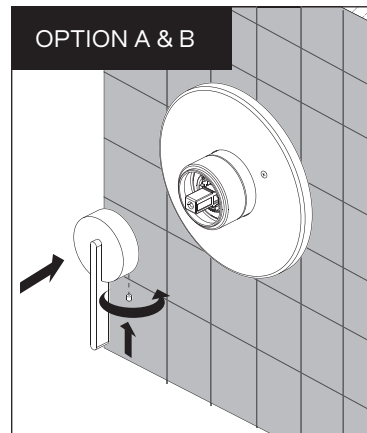
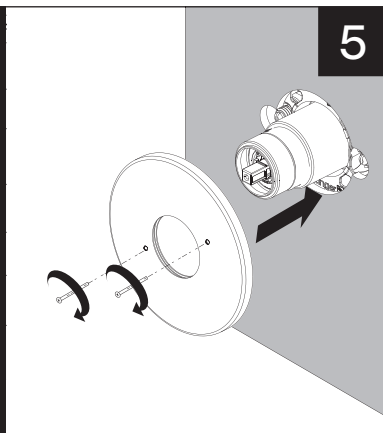

OPTION A & B

6

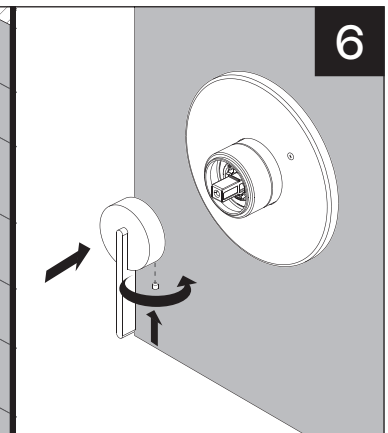

OPTION A & B

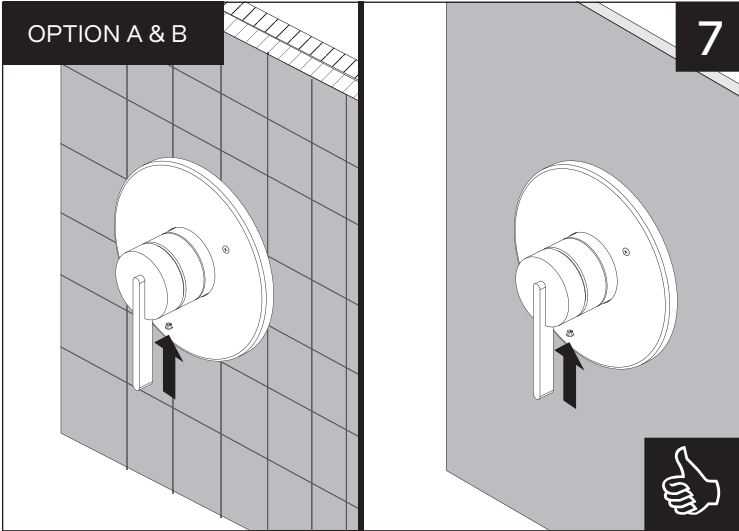

TEMPERATURE LIMITER ADJUSTMENT
AJUSTEMENT DU LIMITEUR DE TEMPÉRATURE

TURN COUNTERCLOCKWISE TO
SET FOR MORE HOT WATER



TOURNER AU SENS ANTIHORAIRE
POUR PLUS D'EAU CHAUDE

TURN CLOCKWISE TO SET
FOR LESS HOT WATER



TOURNER AU SENS HORAIRE
POUR MOINS D'EAU CHAUDE

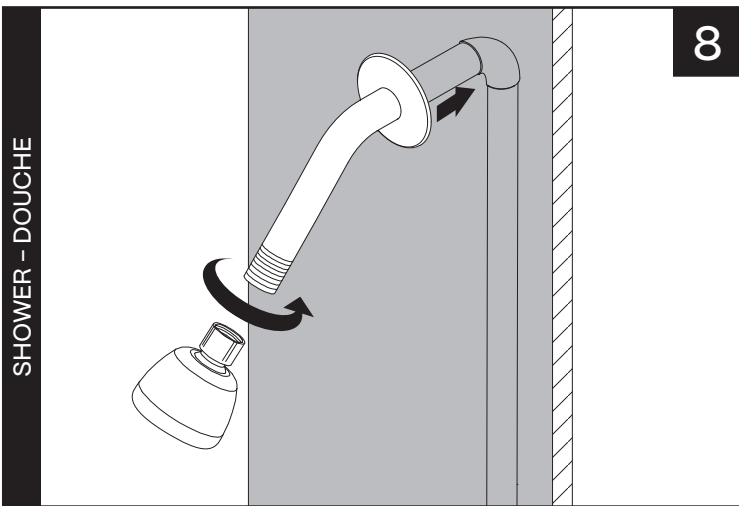

SHOWER - DOUCHE

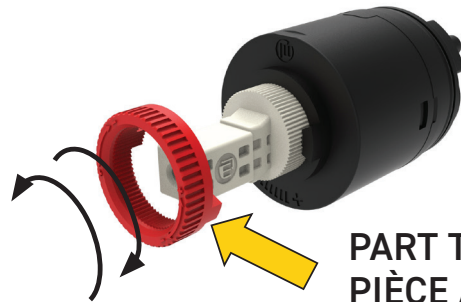

PART TO SET
PIÈCE À RÉGLER

No	Description		Part/Pièce
A	Pressure Balanced Valve Trim	Garniture de valve à pression équilibrée	1000001912
A-1	Handle kit	Ensemble de poignée	1000001920
A-2	Index	Index	HDL4013MB
A-3	Allen screw	Vis Allen	923001
A-4	Trim Cap	Garniture d'écrou	DEC4007MB
A-5	Trim sleeve	Douille de finition	DEC5005MB
A-6	Face plate with seal	Plaque de finition avec joint d'étanchéité	1000001507
A-7	Plate screw	Vis de la plaque de finition	1000001506
A-8	Ceramic cartridge (P)	Cartouche céramique (P)	C9AC010-2
B	Shower arm and flange kit	Ensemble de bras et bride de douche	DEC0002MB
C	Shower head	Pomme de douche	1000001922

